



Australian Railway Kits

ABN: 27 416 246 418

Incorporating Main West Models
Manufacturers, Wholesalers and Retailers of Quality Australian Model Railways
PO Box 252 Warwick, Queensland, 4370 Australia
Phone/Fax: 617 4667 1351 Website: www.arkits.com Email: info@arkits.com

NSWGR C30T 4-6-0 LOCOMOTIVE AND TENDER KIT

E139 Manufactured Exclusively for AR Kits by DJH Engineering from Patterns owned by AR Kits

PLEASE READ INSTRUCTIONS THOROUGHLY BEFORE COMMENCING ASSEMBLY

CONSTRUCTION

It is important to ensure that all parts are clean, free of "flash" (excess metal on castings) and fit properly. The "flash line" is easily removed from most areas by scraping gently with a sharp hobby knife - a round blade is more effective than a straight pointed type. Pull the blade along the "flash line" - several light strokes are better than a single one. Some areas are better cleaned up with 6" jewellers' files. Take care not to flatten round parts by filing too heavily. All locating holes for detail fittings should be pre-drilled to the size specified in the instructions. Sometimes it is necessary to clean out these holes with a "rat tail" file; take care not to snap off the tip of the file. Gently wash the castings in warm soapy water to remove mould release residue.

Etched brass items are best removed from the fret by placing the fret on a scrap piece of hard timber (eg Pyneboard) and cutting the tabs with a large Stanley knife - cut the tab at the point furthest away from the part, then trim the tab off close to the part with a small pair of quality side cutters. Hold small parts with a pair of flat nosed (not serrated jaws) pliers while cleaning up with jewellers' files. Be careful not to distort the etchings; they are difficult to straighten if bent or twisted. Drill all required holes before assembly, noting the spigot sizes of the fittings, because some holes will be difficult to drill after parts are assembled.

This kit contains sufficient parts to make either Saturated, Superheated or Drumhead Superheated versions of the C30T. The three versions are shown on the drawings, therefore during assembly refer to parts listing where alternate parts are marked *. As with all classes of NSWGR locomotives, individual C30Ts varied in minor details from time to time in their life. Modellers are therefore advised to check photographs of the particular locomotive they have chosen to model.

A detailed history of the C30T locomotive is covered in Ron Preston's book "Standards in Steam The 30 Class", and an excellent Data Sheet is also available.

These kits are designed to give many years of operating pleasure. A little extra time taken during construction will ensure that your kit will do this. It cannot be emphasised too strongly that the basis of a smooth operating model is care when constructing the chassis and valve gear, ie you must double check every step. Check that the axles turn freely in their bearings, check again with the coupling rods on, then again with the connecting rods on, etc, etc.

Assembly methods

The two main construction methods are:

(a) Low melt solder - Low melt solder is an excellent medium for use with white metal kits. It is quick and easy providing a stronger joint than can be achieved with glue. It has the added advantage of easily repairing minor casting flaws, and because of the relatively low temperature, many parts can be held in the fingers while soldering. Brass to white metal joints can also be made by "tinning" the brass first with normal solder. Low melt soldering requires the correct type of soldering iron (eg Dick Smith T2200). These irons have temperature control, as low melt solder only requires around 200 degrees Centigrade. You must use special low melting point solder, such as that available from AR Kits.

IT IS ADVISABLE NOT TO ATTEMPT TO SOLDER ANY CASTINGS WITH A STANDARD SOLDERING IRON

(b) Glue - Superglue and Plastibond are two types of glues suitable for use with this kit. Some modellers prefer to superglue major joints first then "fillet" the joint with Plastibond. Small detail parts are best glued with Superglue. Glue is not recommended for those parts needing good electrical contact, such as the tender bogies.

It does not matter which method you choose but dry fitting parts will ensure a good fit.

Electrical

The electrical system used on these kits is called "half live". Looking from the top facing forward the locomotive chassis collects current from the live wheels on the right-hand side, shown as LS (live side) on the drawings. The tender is insulated from the locomotive chassis by a plastic bush and current is collected from the wheels on the left-hand side of the tender.

Cleaning up/Painting

On completion, any areas which were soldered should be washed using a soft brush and methylated spirits. An excellent pressure pack flux remover is available from Dick Smith stores. Then wash thoroughly in warm soapy water. Rinse with clean water and allow to dry thoroughly before applying a suitable self-etch primer.

Spare Parts

Spare parts are available on a replacement basis. Should any part be missing or damaged contact AR Kits for a replacement. Should you have any problems with the Mashima motor please do not attempt to repair it yourself - return the motor to us. Mashima will not replace motors which have been tampered with.

Should you have any queries or problems with construction please drop us a note and we will do our best to advise. Likewise we would be pleased to hear any suggestions you may have for improving the kits or instructions.

General

The following drill sizes are required: 0.5mm, 0.7mm, 0.8mm, 0.9mm,1.0mm,1.2mm,1.6mm, 2.0mm, 2.2mm, 3.7mm.

During construction refer to the drawings at all times. A number of parts are quite similar, so double check if in doubt. Note that attached to the instructions is a photocopy of the lost wax brass castings sprues with each part numbered for easy identification. In the general instructions the part numbers are shown in brackets.

The instructions sometimes refer to the righthand (R/H) and lefthand (L/H) side. This is taken as viewing the model from above and looking forward

To minimise the risk of losing parts, do not remove them from the etched fret or the plastic packing until you are ready to use them. We recommend that you start construction with the tender.

Safety First

These models are not toys and are not suitable for young children. White metal castings contain lead and modellers are advised to wash their hands after working with unpainted white metal castings. When using superglue, solder or when spray painting, ensure your work area is well ventilated

Tender Drawing 1 (Parts 1 - 16)

Take the tender chassis (1) and fold over the six "U" shaped axle spacing plates (1A) onto the sides. Next fold the sides up 90°. Fit front fixing plate (2) before folding up the front beam of the tender chassis. Check that the unit is straight and square and reinforce the inside of the 90° folds with a fillet of solder or glue as shown. Now fix M2 nuts (4x2) and the drawbar pin (3) to the front fixing plate (2). Take the centre and rear fixing plates (5) and (6) and fix M2 nuts (7x2) securely in place. Fix assembled plates (5 and 6) into the slots on the chassis (1). Fix dummy cylinder plates (11x2) to the inside of the chassis (1). Take the brakes (8, 9 and 10) and fold up as shown, locate and fix into slots on the chassis (1) - note the three brakes are different, see drawing.

Short one wheel of each of the tender axles (12x3) using 1.0mm wire - note that one wheel on each axle has been pre-drilled to facilitate this. Fix the cylinder (13) to the underneath of the keeper plate (14). Position wheels into locating slots on the chassis (1), shorted wheels on the same side (see drawing) and hold in place with keeper plate (14) and screws (15x2). Lastly make up brake pull rods unit with (16x2) and 0.7mm dia. wire. The chassis is now ready for fixing to the body in Drawing 2.

Tender Drawing 2 (Parts 17 - 43)

Take the tender back and sides(18) and fold the sides 90° to the back. Note, there are fold lines (etched lines on rear side of detail) to assist in this. Locate the tender back and sides (18) onto the tender footplate (17) and fix securely. Next fold the beam (19) as shown, (this is designed for Kadee coupler No.16) and fix. The Kadee fixing pivot (not included) should be attached at this stage. Take the assembled chassis and locate and fix to the footplate assembly checking that all joints are straight and square. Now fix the side frames (20 and 21) to the underneath of the footplate checking that the axle box locating holes line up with the tender wheel centres, fold over the tabs and fix.

Fold the coal doors in the tender front (22) as shown, fit the tender front (22), the tender floor (23), the coal trough (24), the hand brake stand (25) and the hand brake handle (26) to the front of the tender. Fit the front axle boxes (27x2) and centre/rear axle boxes (28x4) followed by counter levers (29x2) onto the side of the frames. Take the tender top (30) and drill a 0.5mm hole at the front as shown for the fire iron bracket (35). Now fix the tender top (30) into place on the tender body. Complete detailing of the tender, fitting hungry boards (31xpr), water filler (32), coal partition (33), tool box (34), fire iron bracket (35) and fire irons (36x2). Carefully fold up the ladder (37) - see insert drawing - and locate into the slots at the rear of the tender. Add lamp bracket (38), lamps (39x2), buffers (40x2) and brake pipe (41) to the rear of the tender. Lastly, fold up edges of step treads (43x2) and fit to steps (42x2) after folding the edges of these step treads. Secure steps onto the underneath of the footplate.

Locomotive Drawing 1 (Parts 44 - 85),

Remove the cab (44) from the etched fret and fold up as shown. Fix the screw (45) into the locating hole in the cab floor as shown at this stage, as it is impossible to do this once the cab assembly is completed. Fold the back and front of the cab floor (49) as shown and check that it fits into the bottom of the cab. Take the fall plate (47) and glue the plasticard (48) to the underside of the fall plate (47), trimming so it overlaps the three outside edges approximately 0.75mm to prevent it shorting out electrically with the tender. Fold down the two tabs on the fall plate as shown and locate these tabs into the slots in the cab floor (49) using 0.4mm wire to retain it. Check that the fall plate moves up and down freely.

Fit the cab floor into the cab. Continue to detail the inside of the cab with cab sandboxes (50 - pr), cab back head and detail (51) and regulator handle (52).

Assemble the boiler (55) and smoke box parts either (56A saturated version), (57B superheated version) or (58C drumhead superheated version), making sure that the base of the smoke box and firebox are level (this can be achieved by placing the sub-assembly on a flat surface). Next take the footplate (54) and check that it is straight and square. Now locate the cab to the rear of the footplate via screw hole and nut (46), do not secure tightly yet, next secure the boiler and smoke box assembly into position using nut (59) and screw (60). Check that all the assemblies are square.

Saturated version. Fit door (63) to smoke box A, and fit original mainframes (61xpr).

Superheated version. Fit door (63) to smoke box B, and fit extended mainframes (62xpr). **Drumhead**

Superheated version. Fit door (64) to smoke box C, and fit original mainframes (61xpr).

At this stage take the motor/gearbox unit and check that it fits inside the body. Continue detailing the body fitting parts 65 through to 74. Before fitting parts 75 through to 85, note that you have a number of options, depending on the particular locomotive you have chosen to model. These optional parts are highlighted with an * against the part number.

Locomotive Drawing 2 (Parts 86 - 99)

This drawing shows the saturated version, however the optional parts and the piping shown are applicable to the saturated, superheated and drumhead superheated versions. Continue detailing the body, fitting parts 86 through 99, noting that the part numbers highlighted with an * are optional.

Locomotive Drawing 3 (Parts 100 - 106)

Fitting of pipes and handrails as shown in conjunction with brackets and handrail knobs.

Smokebox A: Left hand side: fit brackets (100, 102, 103x2) and medium handrail knobs (105x2). Right hand side fit brackets (100, 101, 102x2) and medium handrail knobs (105x1).

Smokebox B: Left hand side: fit brackets (100, 103x2, 104) and medium handrail knobs (105x1) Right hand side as for Smokebox A.

Smokebox C: Left hand side: fit brackets (100, 102, 103x2) and medium handrail knobs (105x1) Right hand side as for Smokebox A.

The short handrail knob (106) is fitted on the front for all three versions. Continue to use wires as indicated to make up pipes and handrails.

Chassis Drawing 4 (Parts 107 - 135)

Take the chassis frames (108) and (109). Carefully clean out the axle holes with a 3.7mm drill bit and push fit the axle bushes (107x6). The bushes should be a firm fit in the frames, any loose bushes should be soldered in place. The front driving wheel bushes on the inside of the frames require filing flush to the inside for the motor/gearbox (127) fitting. Ensure that you have cleaned any residue from the filed down front axle bushes (107) before fitting the motor/gearbox. Fit the turned brass chassis spacers (110x2) with screws (111x4). Solder in place the front spacing plate (112) and rear spacing plate (113) making sure that the chassis is kept square. Fit tender draw bar assembly using parts 114 through to 120, note that the spring (118) must be cut to length.

The motor/gearbox (127) provided is a very precise mechanism and should be handled accordingly. Should you have any problems with the motor/gearbox, return the unit to Lloyd's Model Railways, do not tamper with it - any tampering will void your warranty.

Test fit the motor/gearbox between the frames - it should be a free fit. If not, you may need to file flush the outside facing of the axle bearings and the bottom retaining screw in the motor/gearbox unit, as shown in the inset drawing. If this is done, pay particular care not get any filing residue into the motor/gearbox mechanism.

Before fitting the driving wheels, note that the insulated wheels are on the L/H side of the chassis as viewed from the top facing forward. Fit the driving wheels, (flangeless in the centre) axles (124x3) and axle washers (125x6) to the chassis with the axle nuts (123x6). The motor/gearbox (127) and the axle gear (126) locate on the first axle as shown on the drawing. The wheels are quartered so that the crank pin on the right hand wheel leads that of the left hand wheel by 90 degrees when the axle rotates forward. Use a Romford axle nut driver to tighten the axle nuts. Note that the axle gear (126) is retained on the axle with a small grub screw. This screw should not be tightened until all the valve gear and brake rodding is fitted, and the chassis is checked for free movement.

Remove the etched counter weights (131x2 and 132x4) from the fret and glue to the wheels as shown. Using a Romford axle nut driver fit the crankpins (133x6). Axle covers (130x6) should be fitted after final assembly and painting.

Chassis Drawing 5 (Parts 136 - 153)

Remove the wheels and motor/gearbox for the fitting of the brake gear. Fold and fix the brake hangers (136) to the chassis. Before adding the motor support block (137) remove 1.5mm from the top, as shown on the drawing. Using 0.7mm wire position the front brakes (143x2) onto the chassis, locate the pull rods (145x2) between the frames and insert the 0.7mm wire at the rear as shown, allowing excess wire as shown in the insert drawing. Add 0.7mm wire to the front of the pull rods, passing it through the front brake shoes. Add brake stretches (144x2), brake cylinder (146) and brake lever (147). Trim excess wire.

Check that the slidebar support bracket (148) fits right down into the slots in the chassis and fix in place. Make up cylinder assemblies using cylinder bodies (151x2), rear cylinder covers (150x2) and front cylinder covers (152x2) OR for the extended smokebox version (153x2). Note that rear cylinder covers are drilled 1.2mm, and front cylinder covers (152) only are drilled 0.7mm and fitted with 0.7mm wire as shown.

Fold the slide bars (149x2) as shown and reinforce the inside of the fold with solder (see insert drawing). Trim the crossheads (156x2) to 15mm (see drawing 8) and test fit the crossheads into the slide bars, you may need to clear out the keyways of the crossheads using a knife-edge file, or you may need to lightly file the inside edges of the slidebars to achieve a good fit.

Fix the slide bar assemblies to the rear of the cylinders and fix the completed cylinder assemblies to the frames checking that they are at the correct angle (centre line of cylinder should align with the axle of the centre driving wheel).

Reassemble motor/gearbox and driving wheels. Solder insulated wire to the motor terminals at the rear, then solder the negative wire to the chassis and the positive wire to the power clip (139), (motor terminals are marked + and -). Loosen the M2 screw (114) a little, fit power clip (139) underneath the screw head and re-tighten. Now fit rear coupling rods (140xpr), front coupling rods (141xpr) and crankpin washers (142x6). Complete both sides and trim off excess crankpins except for the centre ones.

Chassis Drawing 6 (Parts 154 - 170)

Assemble the connecting rods (155xpr) to the crossheads (156xpr) using 14BA screws (154x2) and nuts (157x2). Place crossheads into the slide bars. Place a crankpin washer on the centre axle crank pins followed by the connecting rods, and secure the connecting rods with a crankpin washer (158x2). Fit the cylinder drain cocks (168x2). Note that the slidebar dust covers (159x2), slidebar steps (160x2) and steps treads (161x2) are optional items.

Make up the front bogie unit (162). Fit the wheels to the bogie making sure the shorted wheels are on the right hand side, secure with keeper plates (164x2). Secure the bogie to the chassis using spring (165), washer (166) and M2 nut (167). Secure the chassis to the body with screw (169) and nut (170). Connect the locomotive to the tender and track test your completed model around the curves on you layout before painting. If you have small radius curves you may need to remove some material from the cylinder blocks to avoid "shorting" on the wheels.

Lightly oil the mechanism and test run, checking for electrical "shorts" on sharp curves etc. Also check that the motor does not overheat due to chassis binding.

23 Feb 2009

(139) - C30T - Lost Wax Brass Castings

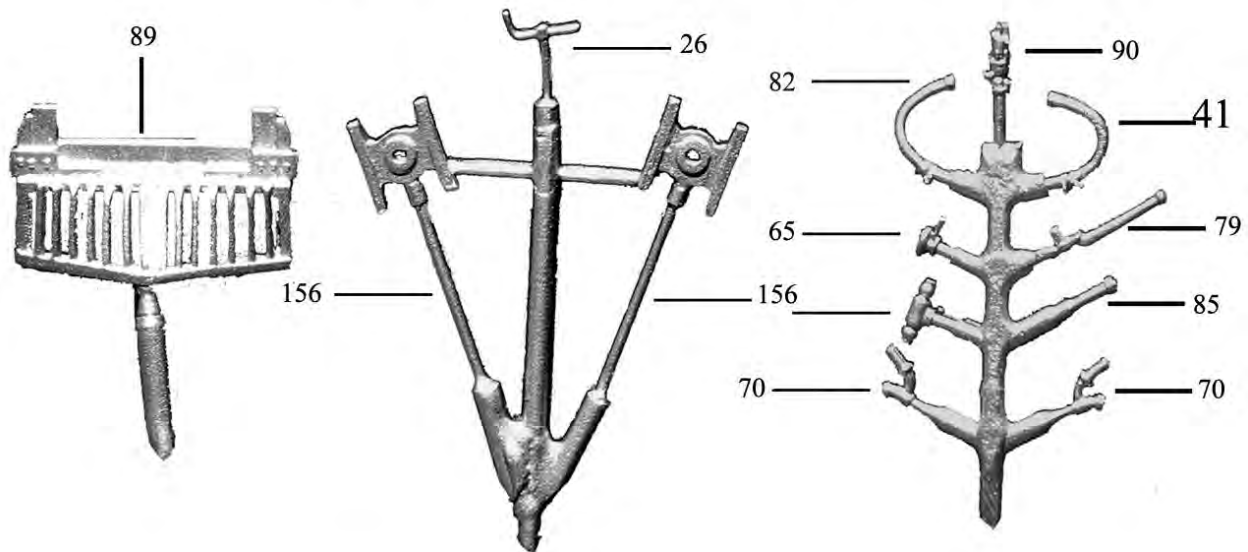

(E139) - C30T - PARTS LIST

Tender Drawing 1.

1.	Chassis	E
2.	Front Fixing Plate	E
3.	Drawbar Pin	T
4.	M2 Nuts x 2	T
5.	Centre Fixing Plate	E
6.	Rear Fixing Plate	E
7.	M2 Nuts x 2	T
8.	Rear Brake and Guard Irons	E
9.	Centre Brake	E
10.	Front Brake	E
11.	Dummy Cylinder Plates x 2	W/M
12.	Tender Wheels x 3	T
13.	Cylinder	W/M
14.	Keeper Plate	E
15.	M2 x 12mm C/S Screws x 2	T
16.	Pull Rods x 2	E

0.7mm dia. Wire

Tender Drawing 2.

17.	Tender Footplate	E
18.	Back and Sides	E
19.	Beam	E
20.	R/H Sideframe	E
21.	L/H Sideframe	E
22.	Tender Front	E
23.	Tender Floor	E
24.	Coal Trough	E
25.	Handbrake Stand	W/M
26.	Handbrake Handle	L/W
27.	Front Axle Boxes x 2	W/M
28.	Centre/rear Axle Boxes x 4	W/M
29.	Counter Levers x 2	W/M
30.	Tender Top	W/M
31.	Hungry Boards x 1 pr	E
32.	Water Filler	W/M
33.	Coal Partition	E
34.	Tool Box	W/M
35.	Fire Iron Bracket	E
36.	Fire Irons x 2	E
37.	Rear Ladder	E
38.	Lamp Bracket	E/M
39.	Lamps x 2	W/M
40.	Buffers x 2	W/M
41.	Brake Pipe	L/W
42.	Front Steps x 1 pr	E
43.	Step Treads x 2	E

Body Drawing 3.

44.	Cab	E
45.	M2 x 12mm C/S Screw	T
46.	M2 Nut	T
47.	Fall Plate	E
48.	Plasticard Insulation	P

49.	Cab Floor	E
50.	Cab Sandboxes x 1 pr	W/M
51.	Cab Backhead Detail	W/M
52.	Regulator Handle	W/M
53.	Cab Roof	W/M
54.	Footplate	W/M
55.	Boiler/Firebox	W/M
56.*	Saturated Smokebox A	W/M
57.*	Extended Smokebox B	W/M
58.*	Superheated Smokebox C	W/M
59.	M2 Nut	T
60.	M2 x 12 C/S Screw	T
61.*	Original Main Frames x 1 pr	W/M
62.*	Extended Main Frames x 1 pr	W/M
63.*	Smokebox Door A and B	W/M
64.*	Smokebox Door C	W/M
65.	Smokebox Door Handle	L/W
66.	Steam Turret	L/W
67.	Safety Valves	W/M
68.	Dome	W/M
69.	Dome Valve	W/M
70.	Clack Valves x 2	L/W
71.	Chimney	W/M
72.	Rear Cab Steps	E
73.	Step Treads x 2	E
74.	Sandboxes x 2	W/M
75.*	Generator	W/M
76.*	Buffer Beam	E
77.*	Buffer Beam	W/M
78.	Buffer Beam Step	E
79.	Handrail Post	L/W
80.	Buffers x 2	W/M
81.	Dummy Coupling	W/M
82.	Brake Pipe	L/W
83.*	Cab Tank	W/M
84.*	Head Lamp C,B	W/M
85.*	Electrical Junction Box	L/W

0.4mm dia. Wire

0.5mm dia. Wire

Body Drawing 4.

86.	Firebox Covers x 2	E
87.	Reversing Rod	E
88.*	Footplate Lift Jacks x 2	W/M
89.*	Cow Catcher	L/W
90.	Whistle	L/W
91.	Generator	W/M
92.*	Headlamp A	W/M
93.*	Headlamp Bracket	E
94.	Lamp Brackets x 4	E
95.	Marker Lights x 2	W/M
96.	Pump	W/M
97.	Air Cleaner	W/M
98.	Guard Irons x 1 pr	E
99.	Split Pins x 2	T

(E139) - C30T - PARTS LIST

0.4mm dia. Wire
0.7mm dia. Wire

Body Drawing 5.

100.	Firebox Handrail Brackets x 2	E
101.	Boiler Handrail Brackets	E
102.	Boiler Handrail Brackets x 3	E
103.	Boiler Handrail Brackets x 2	E
104.	Boiler Handrail Brackets	E
105.	Medium Handrail Knobs x 3	T
106.	Short Handrail Knobs	T

0.4mm dia. Wire
0.7mm dia. Wire

Chassis Drawing 6.

107.	Bushes x 6	T
108.	L/H Frame	E
109.	R/H Frame	E
110.	Frame Spacers x 2	T
111.	Spacer Screws x 4	T
112.	Front Spacing Plate	E
113.	Rear Spacing Plate	E
114.	M2 x 12 c/s Screw	T
115.	Insulation Bush	P
116.	Insulation Washer	P
117.	M2 Nuts x 2	T
118.	Spring	T
119.	Spring Plate	E
120.	Loco Tender Coupler	E
121.	Live Driving Wheels x 2	T
122.	Live Flangeless Driving Wheel	T
123.	Axle Nuts x 6	T
124.	Axles x 3	T
125.	Axle Spacing Washers x 6	E
126.	Axle Gear	T
127.	Motor/Gearbox	-
128.	Insulated Driving Wheels x 2	T
129.	Insulated Flangeless Driving Wheel	T
130.	Axle Covers x 6	E
131.	Large Counter Weights x 2	E
132.	Small Counter Weights x 4	E
133.	Crankpins x 6	T
134.	M2 x 12mm C/S Screw	T
135.	M2 Nut	T

Chassis Drawing 7.

136.	Brake Hangers x 1 pr	E
137.	Motor Support Block	W/M
138.	Insulated Wire 150mm long	P
139.	Power Clip	E
140.	Rear Coupling Rods x 1 pr	E
141.	Front Coupling Rods x 1 pr	E
142.	Crankpin Washers x 6	T

143.	Front Brakes x 1 pr	E
144.	Brake Stretchers x 2	E
145.	Pull Rods x 1 pr	E
146.	Brake Cylinder	W/M
147.	Brake Lever	E
148.	Slidebar Support Bracket	E
149.	Slidebars x 1 pr	E
150.	Rear Cylinder Covers x 2	W/M
151.	Cylinders x 1 pr	W/M
152.*	Leading Cylinder Covers x 2	W/M
153.*	Leading Cylinder Covers x 2	W/M

Insulated Wire
0.7mm dia. Wire

Chassis Drawing 8.

154.	14BA Screws x 2	T
155.	Connecting Rods x 1 pr	E
156.	Crossheads x 1 pr	L/W
157.	14 BA Nuts x 2	T
158.	Crankpin Washers x 2	T
159.*	Slidebar Dust Covers x 2	W/M
160.*	Slidebar Steps x 2	E
161.*	Step Treads x 2	E
162.	Bogie Body	W/M
163.	Bogie Wheels x 2	T
164.	Keeper Plates x 2	W/M
165.	Spring	T
166.	Washer	E
167.	M2 Nut	T
168.	Cylinder Drain Cocks x 2	E
169.	Self Tapping Screw	T
170.	M2 Nut	T

0.7mm dia. Wire

Drill Sizes - Key

0.5mm dia. - A	1.2mm dia. - F
0.7mm dia. - B	1.6mm dia. - G
0.8mm dia. - C	2.0mm dia. - H
0.9mm dia. - D	3.2mm dia. - I
1.0mm dia. - E	3.7mm dia. - J

dh
E139
T1
1-16

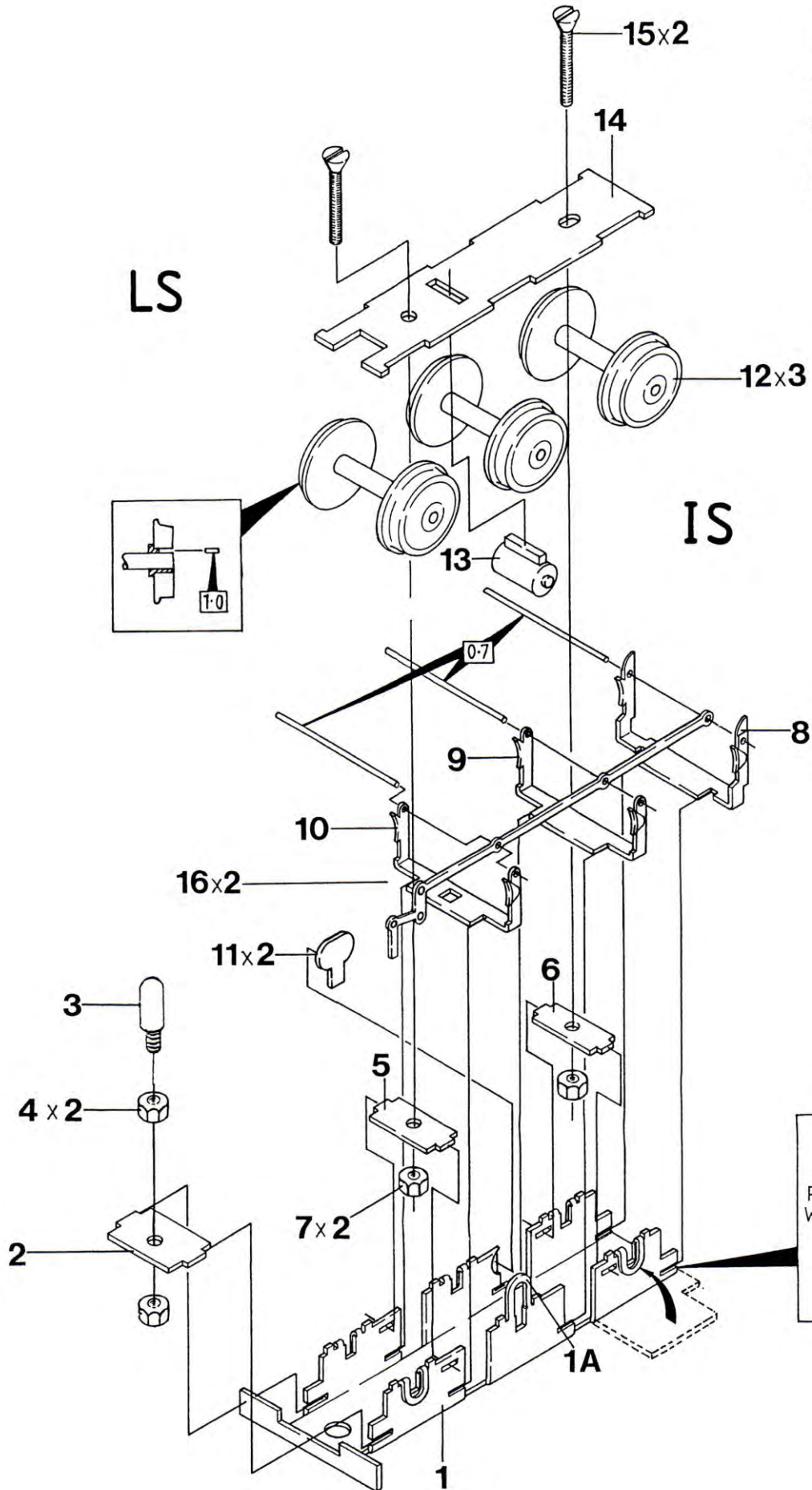

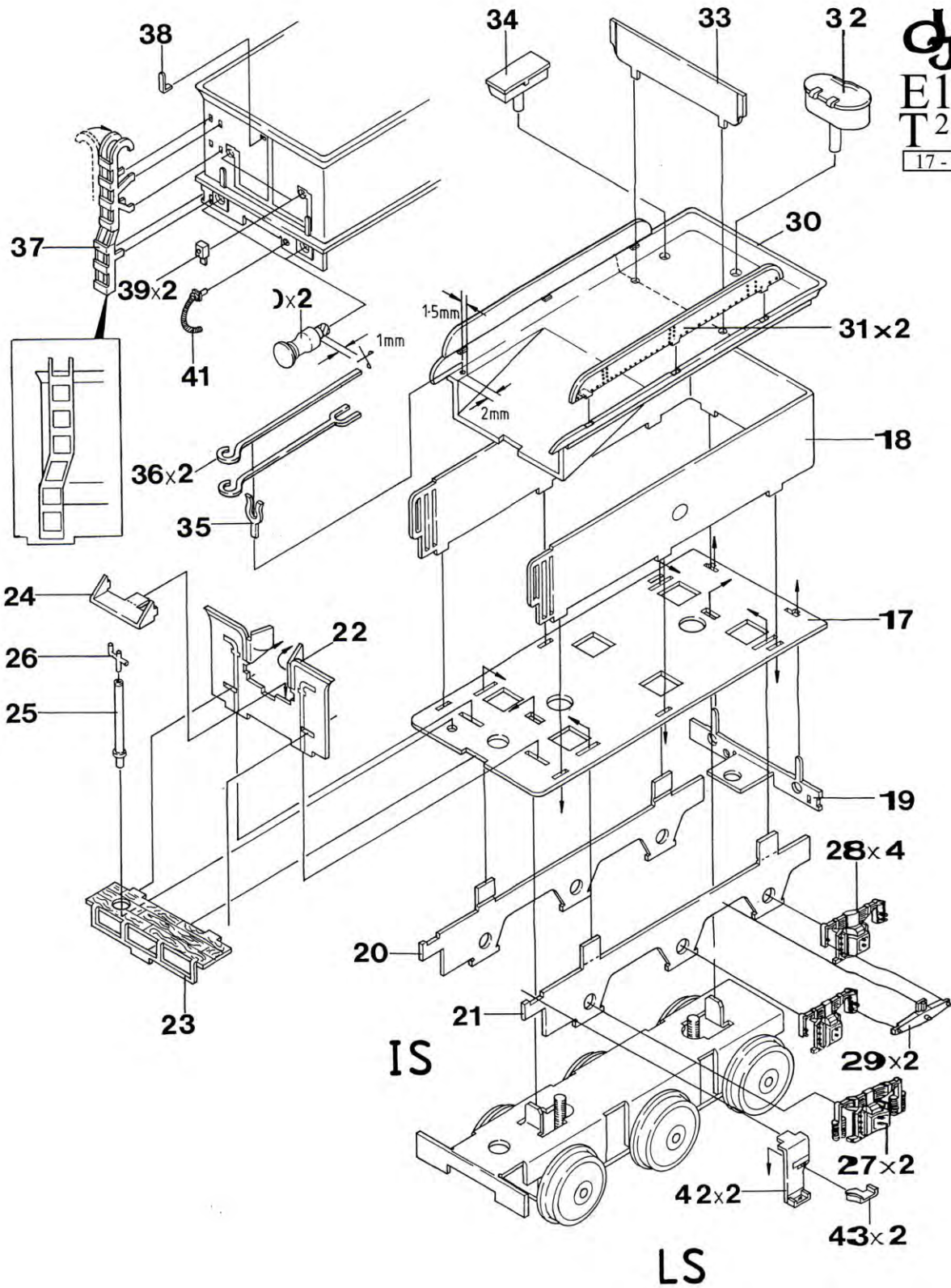

dh

E139

26

86 - 99

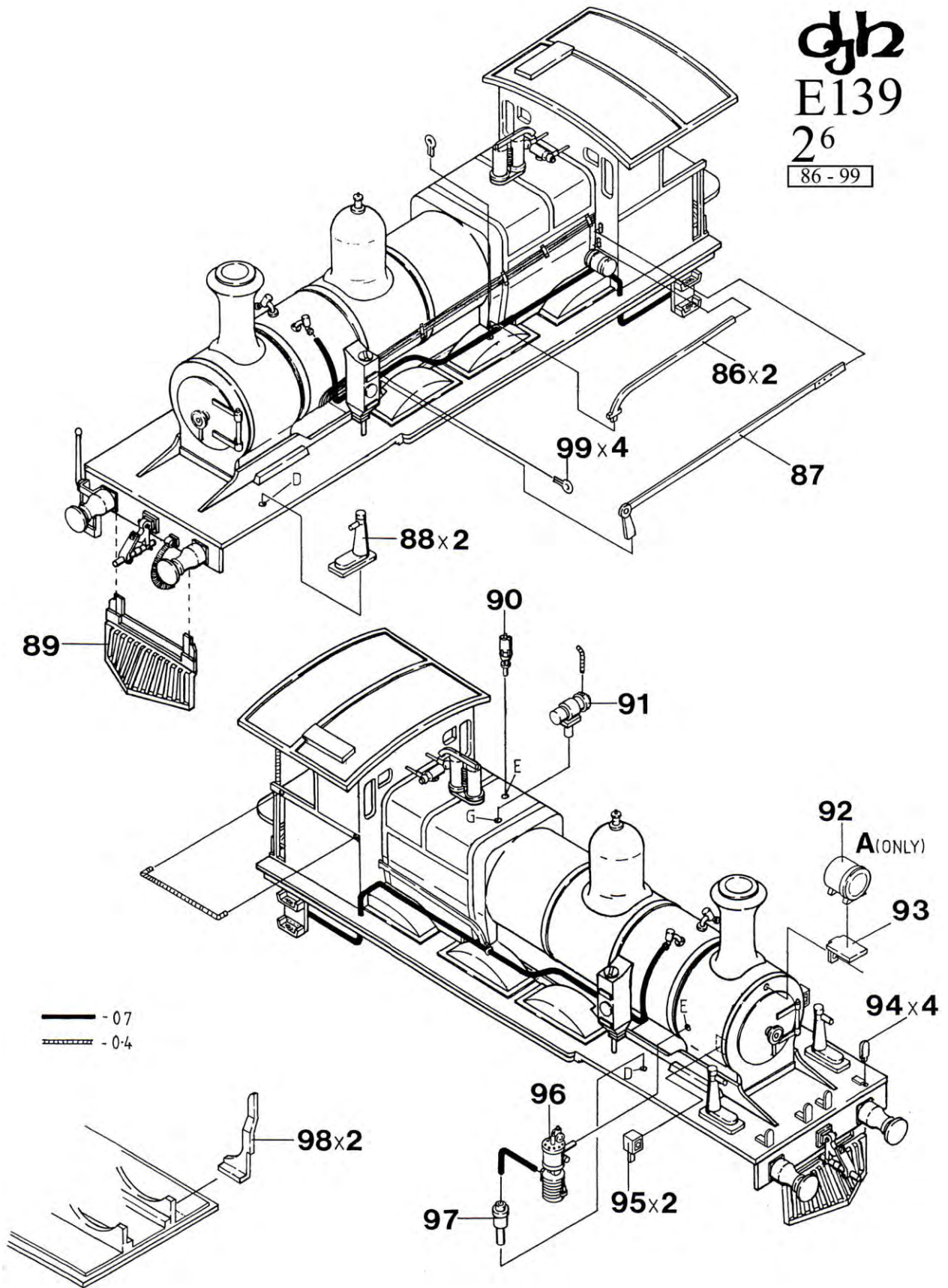

dh
E139
36
100 - 106

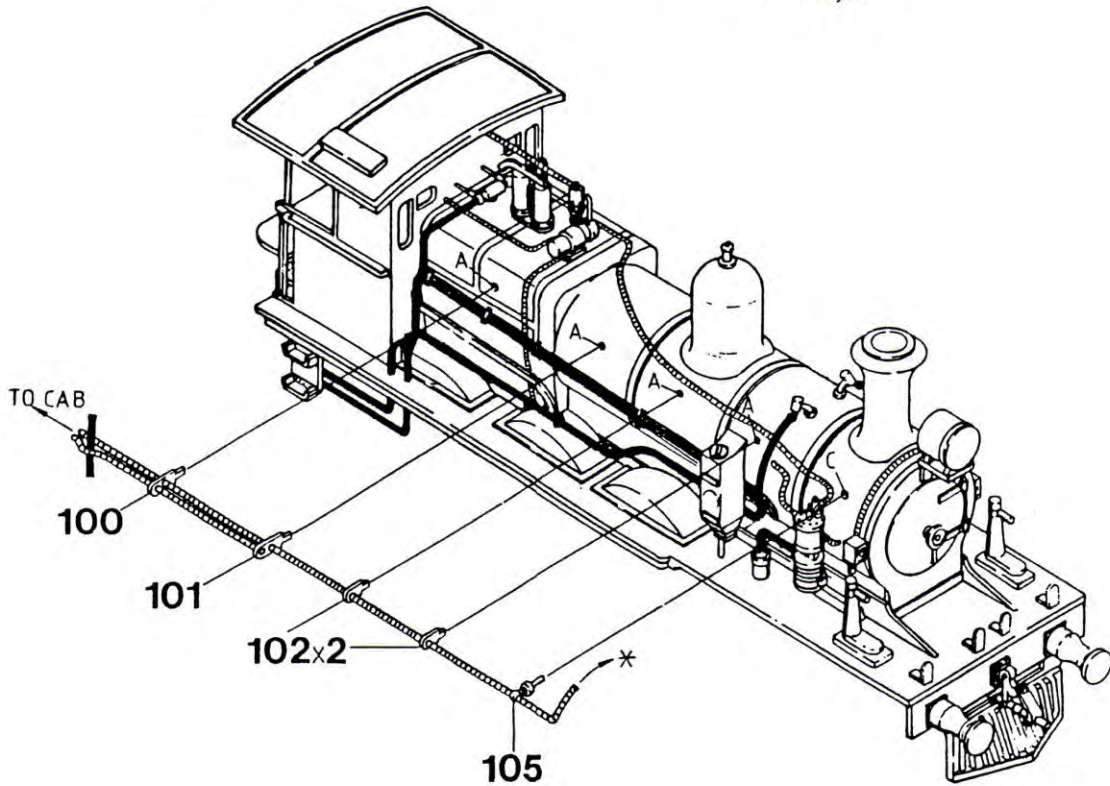
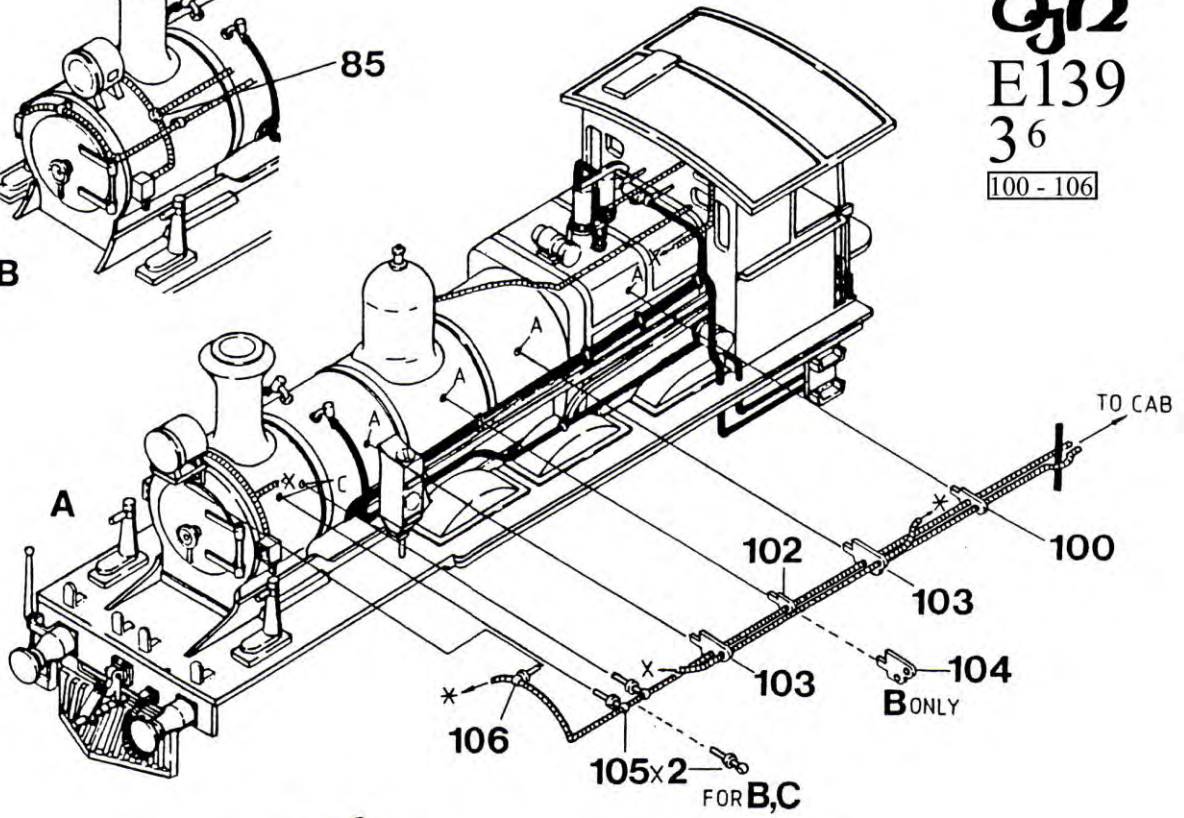
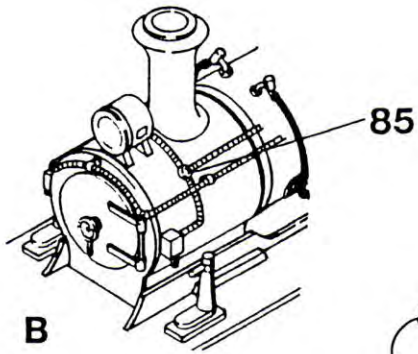

gh

E139

46

107 - 135

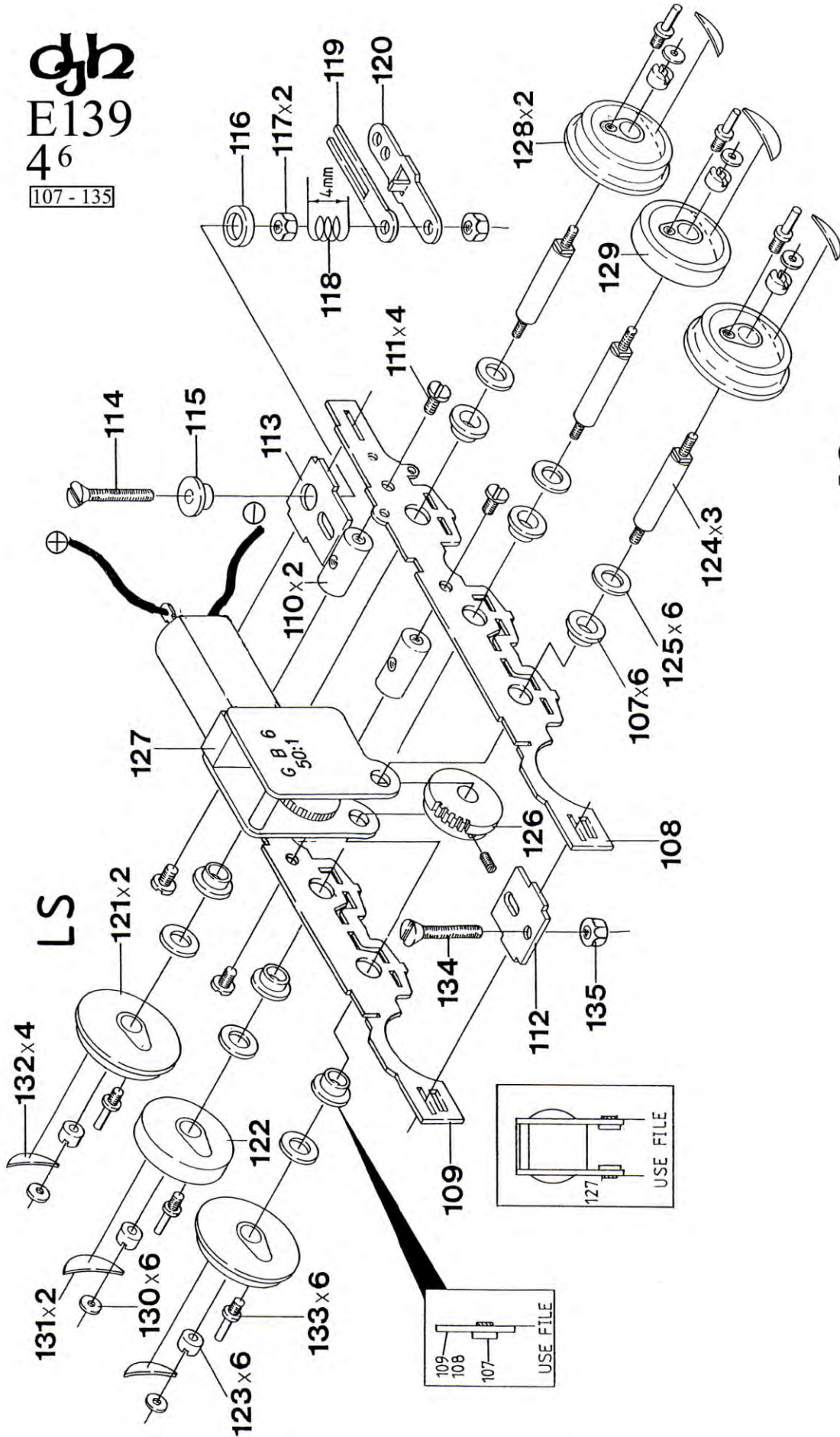

IS

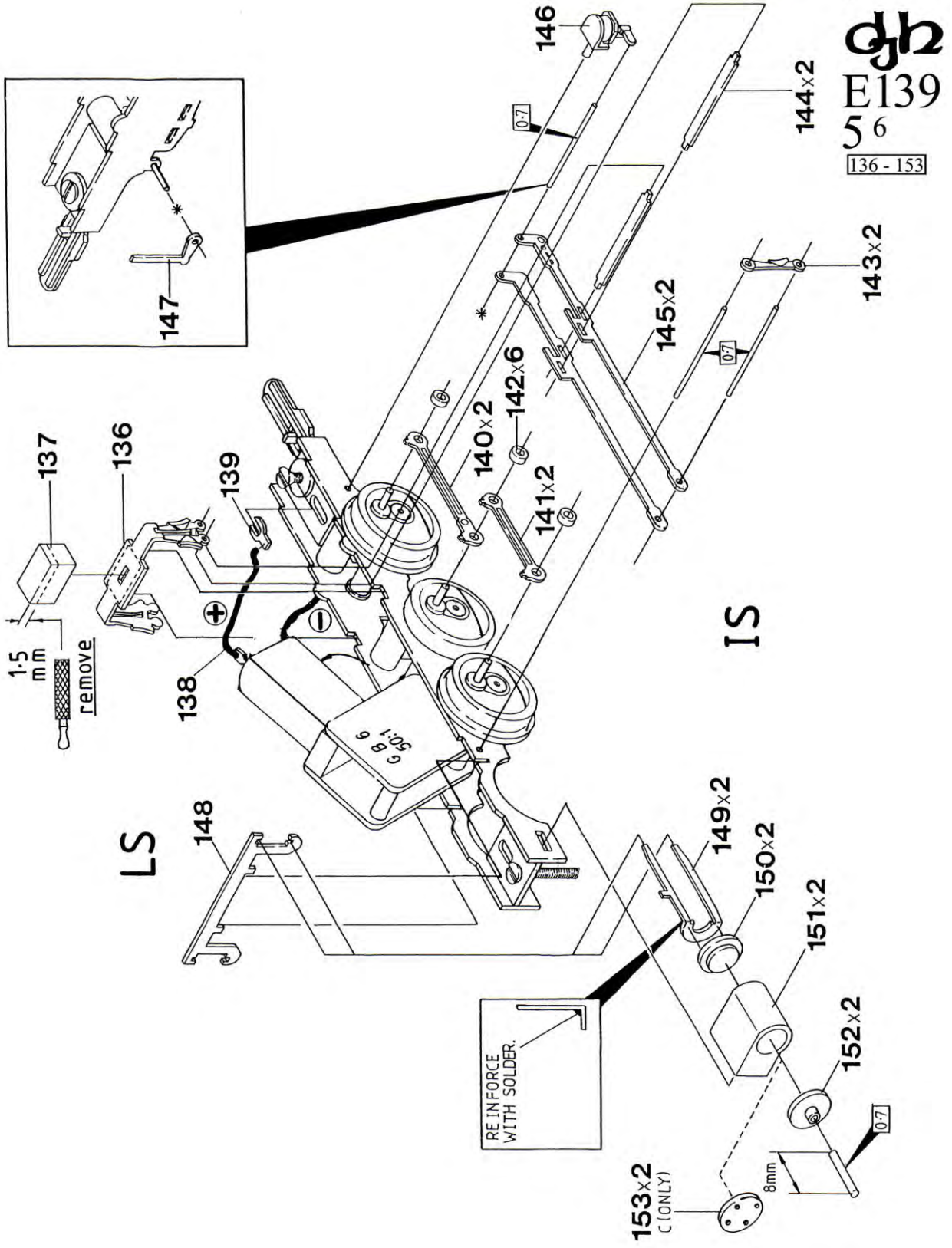

gh
E139
56
136 - 153

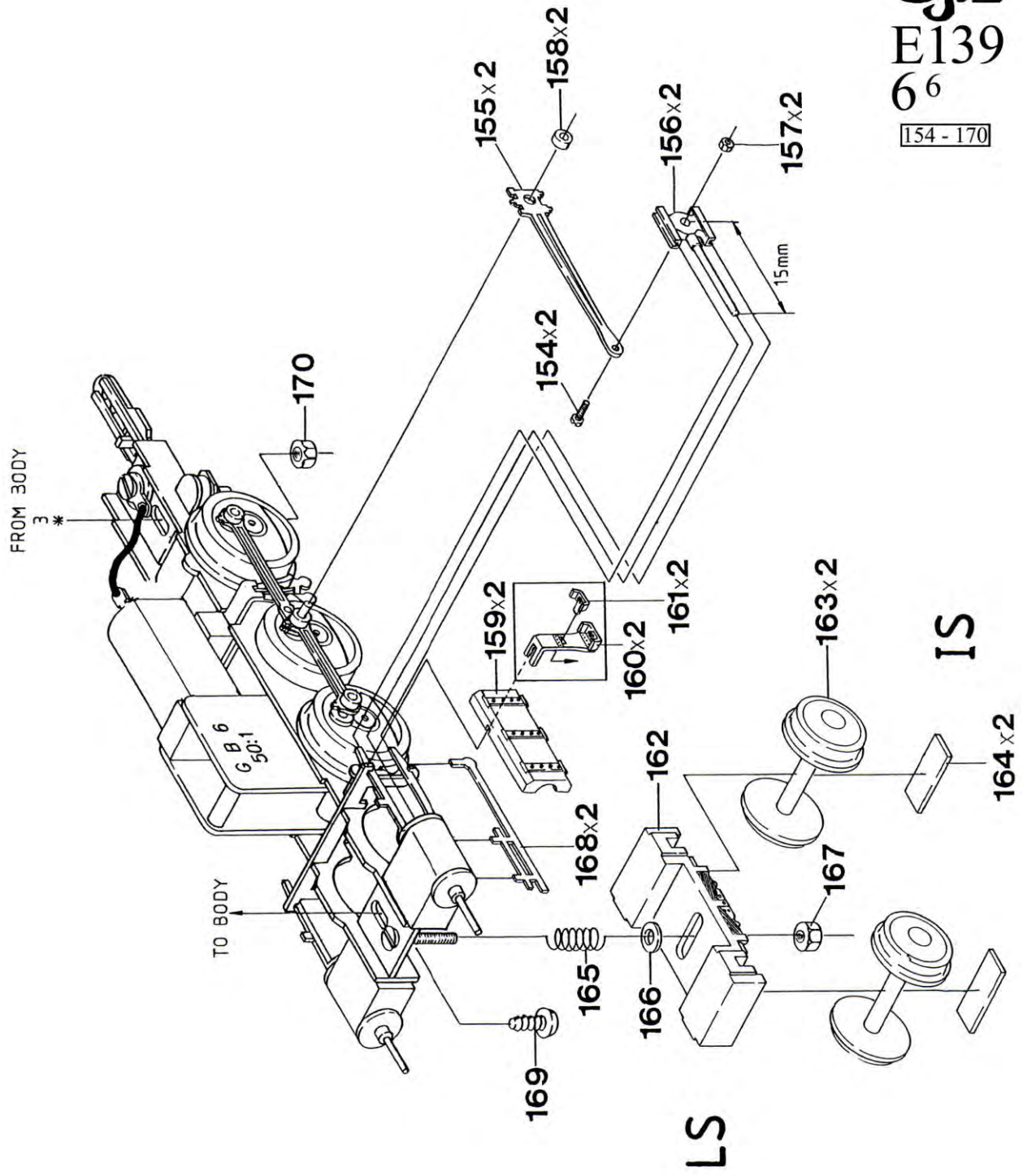

gh
 E139
 6⁶
 154 - 170